

HOTEC

HAND DRYER

SENSOR OPERATED

JET



Reference: 11.113
304 stainless steel satin

COMPONENTS & MATERIALS

- Overall stainless steel food grade 304 satin finish.
- High speed self-developed brushless motor.
- 3 IR sensors in both sides for automatic hands detection.
- HEPA filter which avoids the entry of the tiny particles.
- Internal tank to collect the water and avoid a mess.
- Designed for high traffic bathroom and continuous use.
- Easy maintenance.
- Dimension: 625 high x 290 wide x 198 deep mm.
- Warranty: 3 years.

TECHNICAL SPECIFICATIONS

· Material	304 stainless steel
· Cover thickness	1.0 mm thick
· Voltage/Frequency	AC220V, 50/60Hz
· r.p.m.	19000-20000
· Total power	2200W
· Motor power	700W
· Heating element power	1500W
· Air velocity	90-95m/s
· Air temperature	20-40°C
· Noice level	< 68dB
· Protection level	IP34
· Drying time	5-10s

CERTIFICATE



TECHNICAL DRAWING

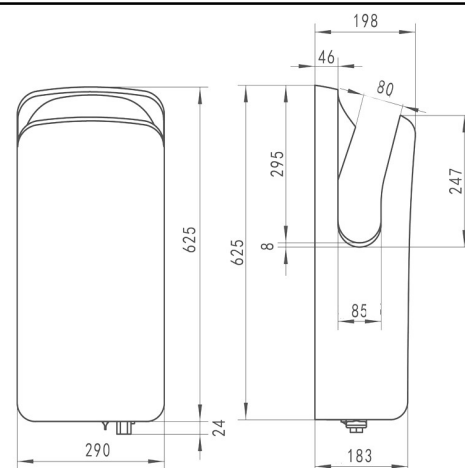

FEATURES

- Overall stainless steel food grade 304, including inner structures & install screws.
- No openings or cracks on the surface, easy to clean dirt, no chance for bacteria survive.
- No fear of fire, burning cigarette butts. Scratch can be repaired.
- Sealing material CR4305.



- Adopting a complete closed structure to protect brushless motor and stainless steel rotor, last up to 10 years.



- Washable with water. Disinfect with disinfectant, ultraviolet rays and hot water.



- Use vacuum cleaner and air blower (colder) to clean HEPA filter.
- Outer filter can be washed for repeated use.
- Warranty: 3 years.

