



**BATHROOM ACCESSORIES**

Double face magnifying mirror

ITEM: 16.634



- Surface-mounted dual-sided swivel vanity mirror.
- Extensible arm.
- Suitable for mounting on the wall.
- Suitable for the hotel sector, for fitting out the bathrooms in the hotel rooms.
- Durability and resistance to corrosion.

**COMPONENTS & MATERIALS**

- Mirror rods and supports, made of brass, chrome finish.
- Mirror arm and base made of AISI 201 stainless steel, bright finish.
- Dimensions: Ø200 mm, maximum arm aprox. 415 mm.
- Rectangular wall support.
- One face normal vision, the other face is a magnifying mirror (x3).
- Equipped with fixing materials.

**TECHNICAL SPECIFICATIONS**

Dimension	Ø200 mm
Maximum arm aprox	415 mm

**TECHNICAL DRAWING**

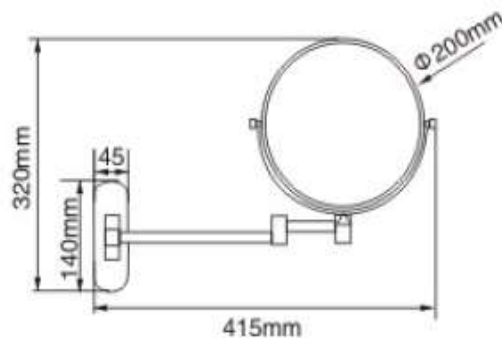

No specific instructions for its use required.